

# MANHATTAN

## 2320OZ

### SMALL WALL MOUNT LANTERN

Manhattan is a classic update to the traditional train station lantern. The hand-painted Oil Rubbed Bronze finish complements the clean lines of its durable die cast construction.

DETAILS	
FINISH:	Oil Rubbed Bronze
MATERIAL:	Aluminum
GLASS:	Clear Beveled

DIMENSIONS	
WIDTH:	7.3"
HEIGHT:	11.8"
WEIGHT:	4lb
BACK PLATE:	4.5"W X 6"H
EXTENSION:	8"
TOP TO OUTLET:	2.5"

LIGHT SOURCE	
LIGHT SOURCE:	LED Lamp
WATTAGE:	1-12w Med. LED, 100W Equiv.
VOLTAGE:	120v

SHIPPING	
CARTON LENGTH:	11
CARTON WIDTH:	10
CARTON HEIGHT:	15.5
CARTON WEIGHT:	5

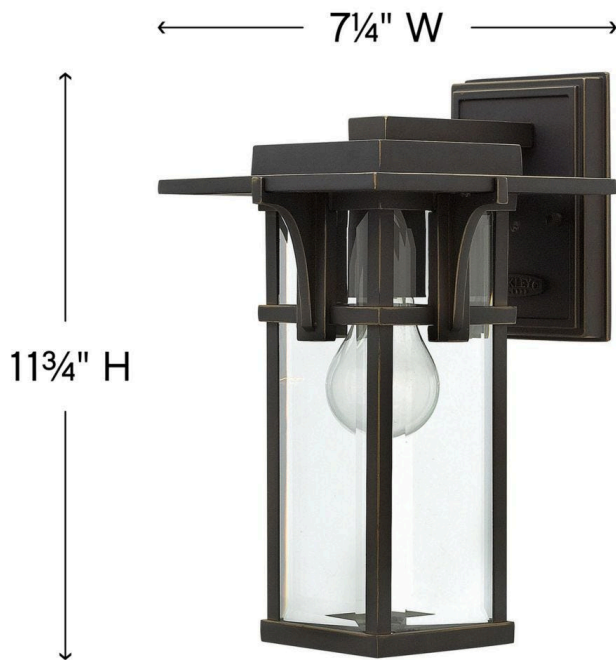

#### PRODUCT DETAILS:

- Suitable for use in wet (outdoor direct rain or sprinkler) locations as defined by NEC and CEC. Meets United States UL Underwriters Laboratories & CSA Canadian Standards Association Product Safety Standards
- Ideal for vintage filament bulbs (not included)
- 2 year finish warranty
- Streamlined forms, robust finishes and symmetrical details complement Craftsman facades
- Bold and robust dark bronze finish

# HINKLEY

HINKLEY  
33000 Pin Oak Parkway  
Avon Lake, OH 44012

PHONE: (440) 653-5500  
Toll Free: 1 (800) 446-5539

[hinkley.com](http://hinkley.com)